

Key Features of Internally-Wired Poles:

- 2-pin MIL connector at pole handle for quick connection to Vibration Analyzer or Ultrasound Instrument
 - Safety breakaway recommended
- Internal cable included inside pole
- Better protection of data collection cable
- Fits most standard-size accelerometers
- 180-degree swivel head for connection points at tough angles



Key Features of Externally-Wired Poles:

- Improves route efficiency
- 180-degree swivel head for connection points tough angles
- Quick access to collection points
- Customizable cable configurations based on specific data collection devices
- External cable sold separately



Physical

Pole Options	Internal Cable	
	External Cable	
Internally Cabled Pole		
Actual Length Extended & Retracted	IE-INTx-24	2ft 5in - 3ft 6in
	IE-INTx-48	4ft 5in - 7ft 6in
	IE-INTx-612	6ft 5in - 11ft 1in
	IE-INTx-816	7ft 5in - 15ft 1in
Externally Cabled Pole		
Actual Length Extended & Retracted	IE-EXTx-24	2ft 5in - 4ft
	IE-EXTx-48	4ft 5in - 8ft
	IE-EXTx-612	6ft 5in - 11ft 7in
	IE-EXTx-816	7ft 5in - 15ft 7in
Weight		
	IE-XXXx-24	1lb 10.7oz
	IE-XXXx-48	2lb 10.20oz
	IE-XXXx-612	3lb 9.90oz
	IE-XXXx-816	4lb 10.50oz
Pole Material		
	Aluminum	
	Fiberglass	

Swivel Range	180 Degrees	
Swivel Material	Anodized Aluminum	
Sensor Sizes	Fits Most Standard Single and Triaxial Accelerometers and SDT Ultrasound Sensors	
Integrated Cable Connection	2-pin MIL Type C-5015	
Sensor Tightening Screw Thread	Hex 9/64 (L-Key Included)	
Head Dimensions	4in x 2in	
Cable Options	Internal External with Safety Breakaway (Suggested)	
Suggested Standard Sized Accelerometers	10 mV/g 100mV/g Low-Cost Low Frequency	50 mV/g 500 mV/g High Temperature High Frequency
Suggested Magnets	Flat Surface Multi-Purpose	



How to Order

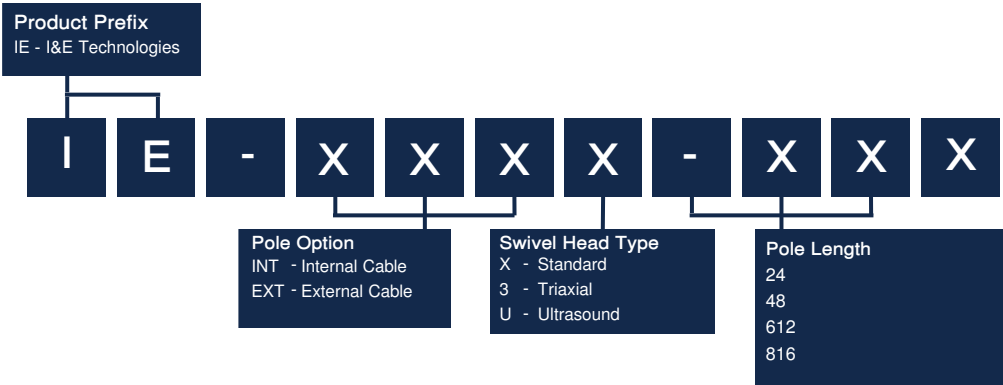

We reserve the right to alter the specification of this product without prior notice.